

THE DAY AFTER

A jig for 4 couples

Two chords – 3rd and 4th couples cross to opposite side on 2nd chord

BARS

- 1 – 8 2nd and 3rd couples dance right hands across and back with left hands, retain left hands and join right hands with nearest corner ie 2nd man with 1st man – 3rd man with 4th man etc.
- 9 – 10 All balance in a saltire.
- 11 – 12 Dropping left hands, all half turn right hand, 1st and 4th couples join left hands.
- 13 – 14 All balance in a saltire.
- 15 – 16 1st and 4th couples dance left hands across half way, 1st couple finish in middle facing ladies side, 4th couple finish in middle facing men's side.
- 17 – 20 4th couple and 2nd man, 1st couple and 3rd man, dance right hands across, then 4th and 1st men followed by their partners dance across to 2nd and 4th ladies respectively.
- 21 – 24 4th couple and 2nd lady, 1st couple and 3rd lady, dance left hands across, 1st couple finish in 3rd place facing up, nearer hand joined, 4th couple finish in 2nd place facing down, nearer hand joined.
- 25 – 26 1st couple making an arch dance up, 4th couple dance under.
- 27 – 28 4th couple making an arch dance up, 1st couple dance under.
- 29 – 32 4th couple dance up round 2nd couple and cast off to 2nd place, as 1st couple dance down round 3rd couple and cast up to 3rd place.

Repeat 3 times from new positions.

Recommended tune: The Strathclyde Jig by Duncan Gillespie

Devised by James McMillan

Originally written for a St Andrew's Night dance, but the event was changed to the following night due to a clash, so the name of the dance changed too.

THE DAY AFTER

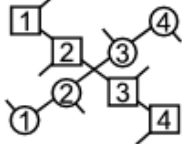
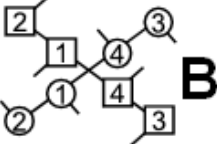
The Day After		J McMillan		4 x 32 Jig
2 chords to <div style="display: flex; justify-content: space-around; margin-top: 5px;"> [1] [2] [3] [4] [1] [2] [3] [4] </div>	<div style="margin-bottom: 5px;"> $\overbrace{\hspace{2em}}^{2\ 3}$ </div> RA LA	 B	All T_{R1/2}	
 B	<div style="margin-bottom: 5px;"> $\overbrace{\hspace{2em}}^{1\ 4}$ </div> LA	to <div style="display: flex; justify-content: space-around; margin-top: 5px;"> [2] [4] [1] [3] [2] [4] [1] [3] </div>	<div style="margin-bottom: 5px;"> $\overbrace{\hspace{2em}}^{2\ 3}$ </div> RA RA	○ leads □ follows
to <div style="display: flex; justify-content: space-around; margin-top: 5px;"> [2] [4] [1] [3] [2] [4] [1] [3] </div> LA LA	to <div style="display: flex; justify-content: space-around; margin-top: 5px;"> [4] [1] [3] [4] [1] [3] </div>	